

Model: ENERGY

EF38

SPECIFICATIONS:

Year of Intro	2000
Thrust	38 LBS
Volts	12VDC
Amp Draw	0 to 48 amps
Mount	01 Bow
Speeds	5 Forward

PARTS ORDERING & TECH ASSISTANCE

MotorGuide Consumer Relations
 Phone 918-831-6989
 Fax 800-982-8093

Returned Goods must be accompanied with a Returned Goods Authorization. Contact MotorGuide Consumer Relations to obtain RGA.

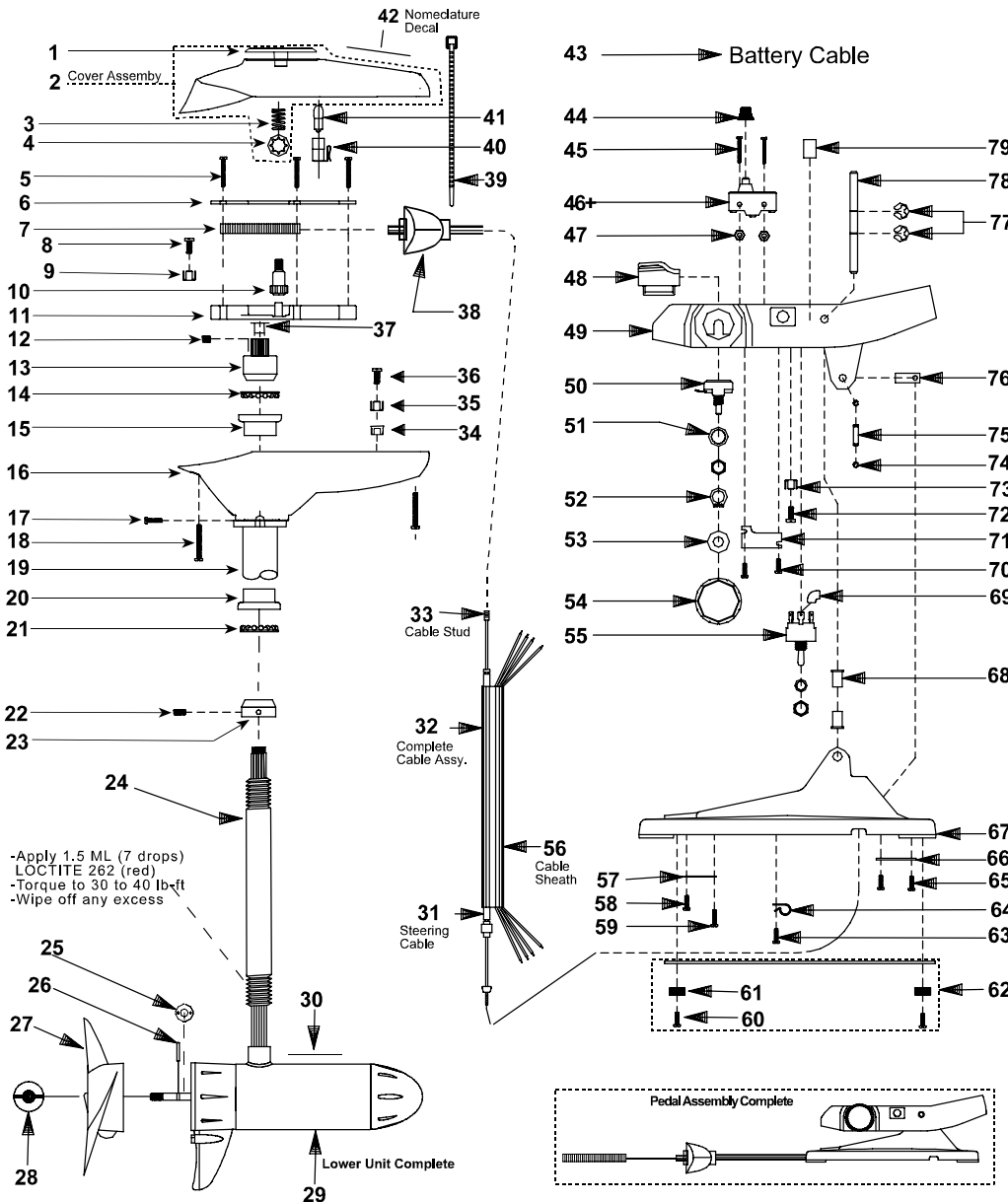

KEY	DESCRIPTION	PART #	KEY	DESCRIPTION	PART #	KEY	DESCRIPTION	PART #
1	RED INDICATOR	AF078-08	29	MOTOR	PF397-04	55	TOGGLE SWITCH 3 POSITIONS	FP153-03
2	T/H COVER COMPLETE BLACK	EF053-17	30	LOWER UNIT DECAL	ET060-07	56	69" ELECTRIC CABLE JACKET	MM9006-03
3	COMPRESSION SPRING	AF014-01	31	63" CONTROL CABLE STUD ASY	9377		63" ELECTRIC CABLE JACKET	MM9006-02
4	TINNERMAN CLIP	AF046-01		69" CONTROL CABLE STUD ASY	9767	57	CABLE PLATE	KP123-01
5	#6 RACK GUIDE SCREW	XF133-01	32	63" CONTROL CABLE ASY	AP327-16	58	#6 SELF TAP SCREW	EK135-01
6	RACK GUIDE COVER	AF127-01		69" CONTROL CABLE ASY	AP327-18	59	6 X 1/2 SCREW	AF135-01
7	RACK	AP125-01	33	CONTROL CABLE STUD	AP141-01	60	6 X 1/2 SCREW	AF135-01
8	#10 X 1/2 SCREW	RT133-03	34	ON SERT PAL NUT	TT098-03	61	FOOT PEDAL PAD	KP023-01
9	TERMINAL (4 PRONG)	FT160-03	35	TERMINAL (4 PRONG)	FT160-03	62	WEIGHT PLATE ASY	LP3123-01
10	INDICATOR GEAR	AF069-01	36	#10 X 1/2 SCREW	RT133-03	63	6 X 1/2 SCREW	AF135-01
11	RACK GUIDE	AF126-01	37	PINION NUT BUSHING	AF021-01	64	CABLE CLAMP	KP036-01
12	1/4 NUT SET SCREW	AF142-01	38	GROMMET	AP071-02	65	SCREW	IR133-01
13	PM PINION NUT	AF398-01	39	CABLE TIE	AF030-01	66	BATTERY CLAMP	KP036-02
14	BEARING	FM005-01	40	LAMP HOLDER	AF394-01	67	FOOT PEDAL BASE	LP003-01
15	BEARING CUP	AF007-01	41	LAMP	AF093-03	68	SHAFT BUSHING	KP021-01
16	T/H BASE BLACK	EF004-16	42	NOMENCLATURE	FF056-20	69	INSULATING SLEEVE	AT080-01
17	RIVET	LF111-03	43	BATTERY CABLE ASY	EP328-07	70	6 X 1/2 SCREW	AF135-01
18	#8 X 5/8 SCREW	AT141-01	44	MICRO SWITCH BOOT	KP157-01	71	RETAINER PLATE	LP123-03
19	42/50" OUTER TUBE	AF165-06	45	#6 32 X 1 1/2 SCREW	LP135-01	72	#10X1/2 SCREW	RT133-03
20	BEARING CUP	FM007-01	46	MICRO SWITCH	AP151-01	73	ON SERT PAL NUT	TT098-03
21	BEARING	FM005-01	47	6 - 32 NUT S.S	SP098-02	74	E RING	FP046-01
22	CONE SET SCREW	AF143-01	48	MICRO BUTTON	LP026-01	75	CABLE PIVOT PIN	AP105-01
23	BEARING CONE	AF006-01	49	FOOT PEDAL	LP101-03	76	CABLE PIVOT	LP091-01
24	42" .105 SS F/O COLUMN	AF049-09	50	ROTARY SWITCH	HF150-01	77	.312 E RING	BK046-02
25	MONOFILAMENT WASHER	AR175-01	51	LOCK WASHER 3/8	KP171-01	78	FOOT PEDAL ROCKER PIN	LP102-01
26	PROP DRIVE PIN	BR102-01	52	GRIP RING	LP046-01	79	SWITCH DECAL	LP057-09
27	PROP	AF124-12	53	NYLON WASHER	AK171-02			
28	PROP NUT	AR099-01	54	SPEED KNOB	LP082-07			

Model:
EF38

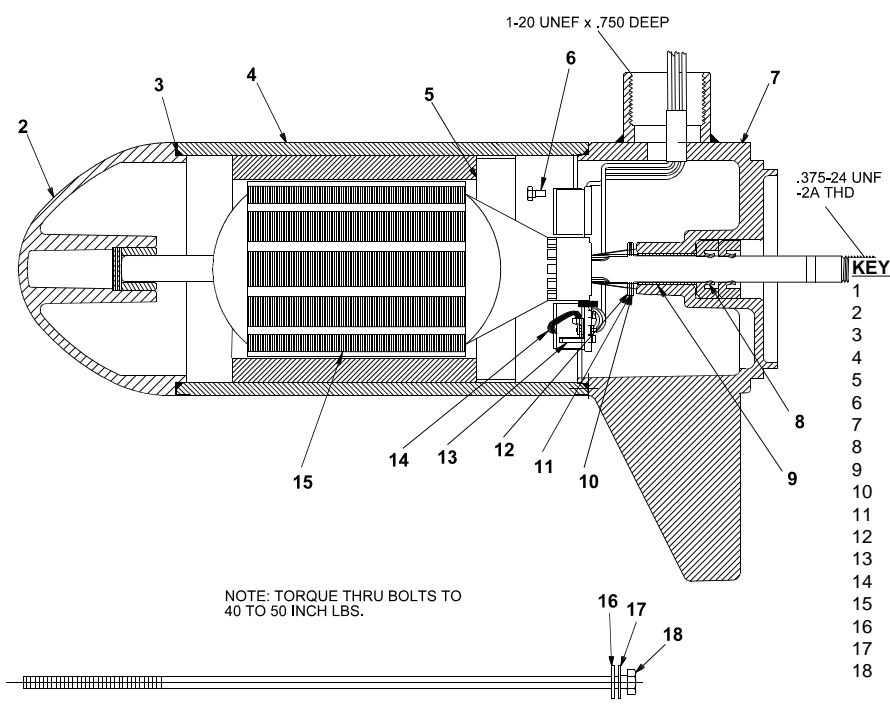

KEY	QTY	DESCRIPTION	PART NO.
1	X	MOTOR	PF397-04
2	1	NOSE CAP	XF3212-01
3	2	O RING SEAL	MR217-01
4	1	HOUSING ASY	PF3210-01
5	1	RETAINER	JF233-01
6	2	BRUSH CARD SCREW	MR228-01
7	1	COMM CAP	PF3205-03
8	2	SHAFT SEAL	MR223-01
9	1	BEARING	MR206-01
10	1	NYLATRON WASHER	MR226-01
11	1	WASHER	MR227-01
12	1	E RING	MR219-02
13	2	BRUSH SPRINGS	MR214-02
14	1	BRUSH ASY LESS SPRING	DF3201-01
15	1	ARMATURE	PF3207-01
16	4	STATIC SEAL	MR222-01
17	4	THRU BOLT WASHER	MR216-01
18	2	THRU BOLT	MR218-14

WIRING

